

# DRAINAGE DEVICE

DD 084 | IP66 / IP67 / IP69K



Photo: Inside view

- > High degree of protection
- > Good drainage performance

- > Easy to install
- > Weather and UV-light resistant

Condensation can occur in enclosures with high protection types by variations in temperature. The use of a DD 084 drainage device allows the removal of the condensate without losing the maximum IP66 protection type. The specific characteristic of the water permeable membrane ensures the drainage of the condensate via capillary action. The unique construction also prohibits the ingress of splash water into the enclosure.



## TECHNICAL DATA

Mounting	thread M50 x 1.5 with nut (wrench size 60 mm, housing 50 mm)
Torque	6 Nm max.
Depth in enclosure	approx. 0.7" (17.5 mm)
Material	plastic according to UL 94V-0, umbra grey, weather and UV light resistant according UL 746C (f1)
Water entry height	0 mm (at 0.5 mm wall thickness)
Sealing	sealing gasket NBR
Water flow-through	approx. 200 ml/hr at 5 mm water column
Dimensions	Ø 2.36" x 1.9" (Ø 60 x 49.5 mm)
Mounting position	horizontal, lowest point
Operating / Storage temperature	-49 to +158 °F (-45 to +70 °C)
Approvals	EAC
Note	Material adheres to limit values in accordance with RoHS3

## Installation

Make cut-out Ø 2.0 inches (50.5<sup>+0.5</sup> mm) in enclosure bottom and mount drainage device with nut. Please make sure that the sealing gasket is put in place on the outer side panel of the enclosure and the hole is free of burrs.

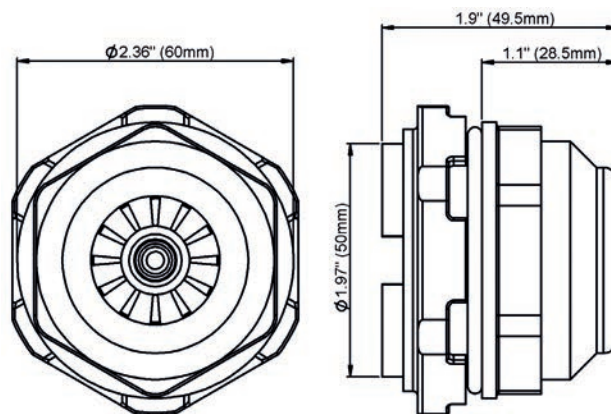
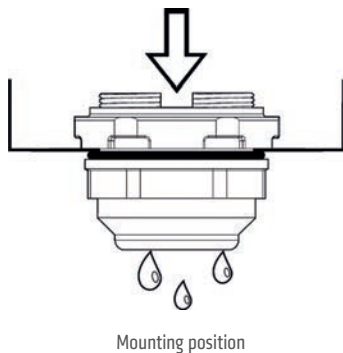

Part No.	Protection type	Enclosure wall thickness	1 package unit	Weight (approx.)
08410.0-00	IP66 / IP67 (EN 60529) / IP69K (EN 40050-9)	0.5 – 5.5 mm	1 piece	2 oz. (60 g)